

homecare



# **SOMNObalance (e)**

**autoCPAP device with exhalation relief  
from SN 65000**

# **SOMNOsoft 2 (e)**

**CPAP device with exhalation relief  
from SN 65000**

*Instructions for use*

**WEINMANN**  
medical technology

# Contents

<b>1</b>	<b>Introduction</b>	<b>4</b>
1.1	Intended use .....	4
1.2	Description of function .....	5
1.3	Contraindications .....	8
1.4	Side effects .....	9
<b>2</b>	<b>Safety</b>	<b>10</b>
2.1	Warnings in this document .....	10
2.2	Operate the therapy device .....	11
2.3	Transport .....	12
2.4	Accessories .....	12
2.5	Repair .....	13
2.6	Handling oxygen .....	13
<b>3</b>	<b>Description of device</b>	<b>14</b>
3.1	Overview of therapy device .....	14
3.2	Control panel .....	15
3.3	Symbols in the display .....	16
3.4	Components .....	17
3.5	Accessories .....	18
3.6	Markings .....	19
<b>4</b>	<b>Operation</b>	<b>22</b>
4.1	Set up device .....	22
4.2	Connect components .....	22
4.3	Connect accessories .....	25
4.4	Operate therapy device .....	29
4.5	Transport therapy device .....	31
4.6	Handling the SD card .....	31
<b>5</b>	<b>Settings</b>	<b>36</b>
5.1	Patient menu .....	36
5.2	Info menu .....	37
5.3	Set softstart .....	39

5.4	Set humidifier .....	40
<b>6</b>	<b>Hygiene treatment</b>	<b>42</b>
6.1	General information .....	42
6.2	Intervals .....	43
6.3	Hygiene treatment for therapy device .....	44
6.4	Hygiene treatment for humidifier .....	46
6.5	Hygiene treatment for breathing tube .....	49
<b>7</b>	<b>Function check</b>	<b>51</b>
7.1	Intervals .....	51
7.2	Check therapy device .....	51
7.3	Check humidifier .....	51
<b>8</b>	<b>Servicing</b>	<b>53</b>
8.1	Intervals .....	53
<b>9</b>	<b>Storage and disposal</b>	<b>54</b>
9.1	Storage .....	54
9.2	Disposal .....	54
<b>10</b>	<b>Faults and display messages</b>	<b>55</b>
10.1	Faults .....	55
10.2	Display messages .....	56
10.3	Humidifier .....	57
<b>11</b>	<b>Appendix</b>	<b>58</b>
11.1	Technical data .....	58
11.2	Scope of supply .....	67
11.3	Warranty .....	69
11.4	Declaration of conformity .....	69

# 1 Introduction

## 1.1 Intended use

### 1.1.1 SOMNO*balance* (e)

SOMNO*balance* (e) is an autoCPAP device for treating sleep-related respiratory disorders. APAP mode can be used in those aged 12 years upwards. CPAP mode can be used in those aged 3 years upwards.

The device generates a positive airway pressure (= PAP) which keeps the patient's airway open as he or she sleeps. The pressure is administered by a nasal, nasal cushion or full-face mask.

SOMNO*balance* (e) detects respiratory events and varies airway pressure accordingly. This allows efficient therapy control.

SOMNO*balance* (e) is an autoCPAP sleep therapy device with CPAP and autoCPAP modes. Exhalation relief (softPAP) can be set as an option. softPAP increases patient comfort by reducing pressure briefly when switching from inspiration to exhalation.

The device can be operated with or without the SOMNO*agua* humidifier. The device shows therapy data in the display.

#### Note

- SOMNO*balance* (e) only prevents airway blockage reliably if the upper and lower pressure limit prescribed by the doctor on a patient-specific basis has been determined and set appropriately, for example in a sleep laboratory.
- SOMNO*balance* (e) is not suitable for life-support purposes.

### 1.1.2 SOMNO*soft* 2 (e)

SOMNO*soft* 2 (e) is a CPAP device for treating sleep-related respiratory disorders in persons aged 3 years and above. The device generates a positive airway pressure (= PAP) which keeps the patient's airway open as he or she sleeps. The pressure is administered by a nasal, nasal cushion or full-face mask.

SOMNO*soft* 2 (e) detects respiratory events. This allows efficient therapy control.

SOMNO*soft* 2 (e) is a CPAP sleep therapy device. Exhalation relief (softPAP) can be set as an option. softPAP increases patient comfort by reducing pressure briefly when switching from inspiration to exhalation.

The device can be operated with or without the SOMNO*aqua* humidifier. The device shows therapy data in the display.

#### **Note**

- SOMNO*soft* 2 (e) only prevents airway blockage reliably if the CPAP pressure prescribed by the doctor on a patient-specific basis has been determined and set appropriately, for example in a sleep laboratory.
- SOMNO*soft* 2 (e) is not suitable for life-support purposes.

### **1.1.3 SOMNO*aqua***

The SOMNO*aqua* humidifier is an accessory available as an option for the Weinmann therapy devices SOMNO*balance* (e) and SOMNO*soft* 2 (e).

The SOMNO*aqua* humidifier is used to heat the air flow generated by the therapy device and to increase its humidity. This prevents the upper airways of the patient drying out during therapy.

Operation with third-party devices is not permitted. Use the device solely for the purpose mentioned here.

## **1.2 Description of function**

### **1.2.1 Therapy device**

A fan takes in ambient air through a filter and pumps it through the tube system and the mask to the patient.

During sleep, the patient's airways are braced by the air pressure generated.

The therapy device analyses the pressure and respiratory flow signal and detects respiratory events (such as apneas, hypopneas, flow limitations and snoring).

In APAP mode (SOMNO*balance* (e) only), therapy pressure is automatically increased in the event of obstructive respiratory events, but no higher than the upper pressure limit prescribed by the doctor. Once the events are over, therapy pressure is slowly reduced again.

### **softPAP mode**

In softPAP mode, the respiratory flow curve is continuously evaluated to detect transitions between inspiration and exhalation at an early stage. Before the transition to exhalation, therapy pressure is reduced to relieve exhalation. Before the start of the next inspiration, pressure is increased back up to the therapy value.

If apneas or flow limitations occur during sleep, softPAP mode is automatically deactivated for the relevant period. softPAP mode is likewise temporarily deactivated if respiratory frequency is too high. Therapy pressure remains reduced during this time if no apneas, flow limitations or artifacts occur.

### **Auto on/off**

Auto on/off can be activated on the therapy device. The therapy device can be switched on by the patient taking a breath into the mask. If there is no pressure for approx. 5 seconds (e.g. because the mask has been removed), the therapy device will switch off automatically.

### **Softstart/initial pressure**

To facilitate falling asleep, the doctor can set a pressure different from optimum therapy pressure. This pressure is administered only for a certain period of time (maximum 30 minutes). The pressure limits slowly rise or fall to optimum therapy pressure throughout this period.

- Softstart function: when the device is switched on, the therapy device sets the pressure to the softstart pressure specified by the doctor. The pressure limits then slowly rise to the therapy pressure. This function is suitable for patients who find high pressure unpleasant when awake.
- Initial pressure function (only on SOMNO*balance* (e) in APAP mode): the pressure remains at a set value during the initial period. Once the initial time has elapsed, pressure is reduced to the lower pressure limit. This function is suitable for patients who find low pressure unpleasant when awake or who require a high pressure rapidly after falling asleep.

### **Mask test**

The therapy device can be used to check whether the mask is correctly fitted. Leaks due to a poorly-fitted mask often only occur at relatively high pressures. To check that the mask is leaktight, it is possible to output a higher pressure during the first 30 seconds after the therapy device is switched on.

### **Therapy data**

The therapy device contains an SD card which stores your therapy data and the individual configuration of your device. You can take the SD card with you to your doctor without transporting the therapy device. This enables your doctor to evaluate the data or make modifications to your therapy device.

### **Therapy journal**

There is the option of storing a therapy journal on the SD card. If your doctor has activated this function, the therapy device saves a csv file on the SD card which you can transfer to your PC and edit there. The file has an exchange format which can be read by a variety of programs (e.g. Microsoft® Excel®).

You can also download the SOMNO*journal* application from [www.weinmann.de](http://www.weinmann.de). Following installation the data stored in the csv file can be viewed with SOMNO*journal*, so allowing you to control your therapy.

## 1.2.2 Humidifier

You can use the humidifier to prevent the upper airways drying out during therapy.

The air from the therapy device passes over the surface of a heated water supply. This increases the humidity and temperature of the air flow.

You can set the heating stage on the therapy device on an individual basis.

The transparent humidifier chamber allows you to check the water level at any time.

## 1.3 Contraindications

The therapy device should be used with particular caution or not at all with some diseases.

- cardiac decompensation
- severe cardiac arrhythmias
- severe hypotension, especially in combination with intravascular volume depletion
- severe epistaxis
- high risk of barotrauma
- severe pulmonary diseases (e.g. COPD, pulmonary emphysema)
- diurnal hypoxemia
- respiratory insufficiency due to a cause other than OSA (obesity hypoventilation syndrome)
- nocturnal hypoxemia due to a cause other than OSA (obesity hypoventilation syndrome)
- pneumothorax or pneumomediastinum
- pneumocephalus
- skull trauma



- status following brain surgery and following surgical intervention on the pituitary gland or the middle/inner ear
- acute sinusitis, otitis media or perforated eardrum
- dehydration

In each case the decision whether to use *SOMNObalance* (e) or *SOMNOsoft 2* (e) for therapy lies with the doctor in charge. Dangerous situations involving this therapy device have never been observed.

## 1.4 Side effects

When using the therapy device, the following undesired side effects may occur in short-term or long-term use:

- pressure points on the face from the breathing mask and forehead cushion
- reddening of facial skin
- blocked nose
- dry nose
- dry mouth in the morning
- sensation of pressure in the sinuses
- irritation of the conjunctiva of the eyes
- gastrointestinal insufflation of air ("bloating")
- nosebleeds

These side effects are general side effects of therapy with a sleep therapy device and are not attributable specifically to the use of *SOMNObalance* (e) or *SOMNOsoft 2* (e).

## 2 Safety

Read these instructions for use through carefully. They are a constituent part of the devices described and must be available at all times.

Use the device only for the intended use described (see "1.1 Intended use" page 4).

For your own safety and the safety of your patients and in accordance with the requirements of Directive 93/42/EEC, follow the safety instructions below.

### 2.1 Warnings in this document

Warnings indicate information relevant to safety.

Within instructions, you will find warnings in front of a step which contains a hazard to persons or objects.

Safety instructions consist of

- the warning symbol (pictogram)
- a word to indicate the level of hazard
- information about the hazard and
- instructions on how to avoid the hazard.

There are three levels of warning instruction, depending on the degree of hazard.

 **DANGER**

Indicates an unusually great hazard. If you do not follow this instruction, severe irreversible injuries or death will result.

 **WARNING**

Indicates an unusually great hazard. If you do not follow this instruction, severe irreversible or fatal injuries may result.

 **CAUTION**

Indicates a hazard. If you do not follow this instruction, mild or moderate injuries may result.

**NOTICE**

Indicates material hazards. If you do not follow this instruction, material damage may result.

## 2.2 Operate the therapy device

- The device can be operated with the power supply unit provided on voltages from 115 V to 230 V. Ensure that your supply voltage falls within this range. For operation on 12 V DC or 24 V DC, use DC adapter WM 24469 which is available as an accessory.
- The device must be connected to an easily accessible socket so that the plug can be disconnected quickly in the event of a fault.
- Do not set up the device close to a radiator and do not expose it to direct sunlight, as this could heat up the respiratory air and internal parts further. This could cause condensation to form in the humidifier which would then be deposited in the tube system.
- Do not cover the device with blankets etc. This would block the air inlet and the device might overheat. This may lead to inadequate therapy and damage to the device.
- Ensure that no dirt gets into the therapy device or the humidifier.
- The therapy device is subject to particular precautions with regard to EMC and must be set up and commissioned in accordance with the EMC instructions contained in the accompanying documentation.
- Maintain a safe distance between the therapy device and devices which emit HF radiation (e.g. cell phones) (see "11.1.5 Safety distances" page 66), otherwise there may be malfunctions. If the therapy device interferes with other devices (e.g. a radio), place it at a greater distance from that device.
- Do not operate the therapy device and the humidifier if the device is not working properly, if parts are damaged and/or if the humidifier is wet at the contact of the heater rod.
- The output of the humidifier may change if the device is operated outside the permitted ambient temperatures.
- Do not use the humidifier on patients whose airways have been bypassed.

- Please also see the instructions for use for your breathing mask.
- In the event of a device failure, take off the mask as soon as possible. First check whether there has been a power failure. Follow the instructions for use for your exhalation system.
- Please observe the section entitled "Hygiene treatment" to prevent infection or bacterial contamination.
- If the therapy device is intended for use by several patients, you should use a bacteria filter to protect against infections. It is installed between the breathing tube and the adapter. If the device is to be used for a different patient without using a bacteria filter, you must subject the device to a hygiene treatment beforehand. This must be performed by the manufacturer, Weinmann, or by an authorized specialist dealer.
- Use only branded SD cards which meet the specifications (see "11.1 Technical data" page 58). Functionality may be restricted or data may be lost in the case of SD cards not ordered through Weinmann. Do not use the SD card for third-party files.

## 2.3 Transport

- Do not transport or tilt the therapy device with the humidifier attached. If the humidifier is at an angle, residual water from it may run into the therapy device and damage it.
- Transport the therapy device only with the cover fitted so that no dirt can penetrate the device.

## 2.4 Accessories

- If third-party items are used, functional failures and bioincompatibility may occur. Please note that in these cases, any claim under warranty and liability will be void if neither the accessories nor genuine replacement parts recommended in the instructions for use are used.
- Third-party makes of mask may only be used with the consent of the manufacturer, Weinmann. The success of therapy is jeopardized by the use of non-approved masks.

- Ensure that the accessories used for therapy are suitable and complete. This applies to the exhalation system in particular, The CO<sub>2</sub> content of the exhaled air may otherwise obstruct your breathing.

## 2.5 Repair

- Have servicing and repair work performed only by the manufacturer, Weinmann, or by professional staff.
- It is not permitted to modify the therapy device and humidifier.

## 2.6 Handling oxygen

- If oxygen is used during therapy, smoking and naked flames are prohibited. Risk of fire. Oxygen may accumulate in clothing, bed-linen or in hair. It can be removed only by thorough ventilation.
- An oxygen supply is only permitted if the WM 24042 O<sub>2</sub> connection valve is used. Valves of third-party manufacture may only be used following authorization by the manufacturer, Weinmann. If unauthorized valves are used, there is a risk of fire.
- On the topic of oxygen, it is essential to follow the safety instructions in the instructions for use of your oxygen supply system and the O<sub>2</sub> oxygen valve.
- Oxygen must be supplied via the breathing mask. Supply via any other point is not permitted. The quantity of oxygen supplied must not exceed 4 l/min. If excessive quantities are supplied, there is a risk of fire.

## 3 Description of device

### 3.1 Overview of therapy device

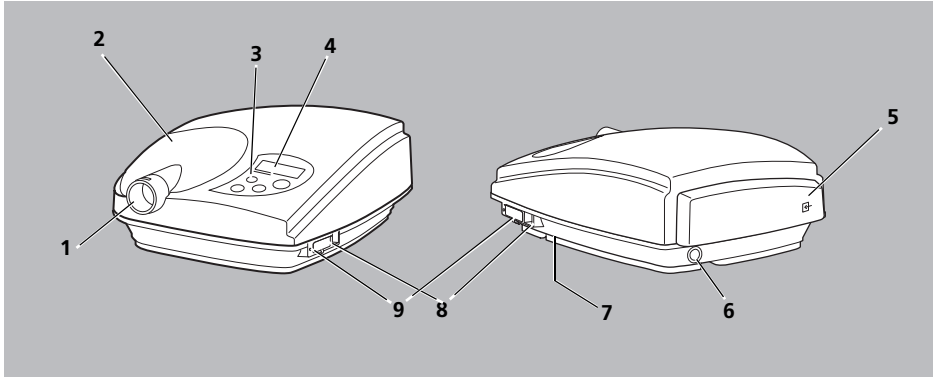

No.	Name	Description
1	Device outlet port	Supplies the patient with air.
2	Cover	Covers the humidifier connection if no humidifier is connected.
3	Control panel	Allows settings to be made to the therapy device (see "3.2 Control panel" page 15).
4	Display	Displays settings and current values (see "3.3 Symbols in the display" page 16).
5	Filter compartment cover	Covers coarse dust filter and fine filter. This is where respiratory air is taken in.
6	Power input	Connects the therapy device to the power supply unit.
7	Device ID plate (not seen)	Supplies information about the therapy device (see "3.6.3 Markings on the device ID plate" page 20).
8	Serial interface	Connects the therapy device to devices for setting and evaluating therapy data or to the O <sub>2</sub> supply valve.
9	SD card slot with LED	Takes an SD card. The LED displays communication between the SD card and the therapy device.

## 3.2 Control panel

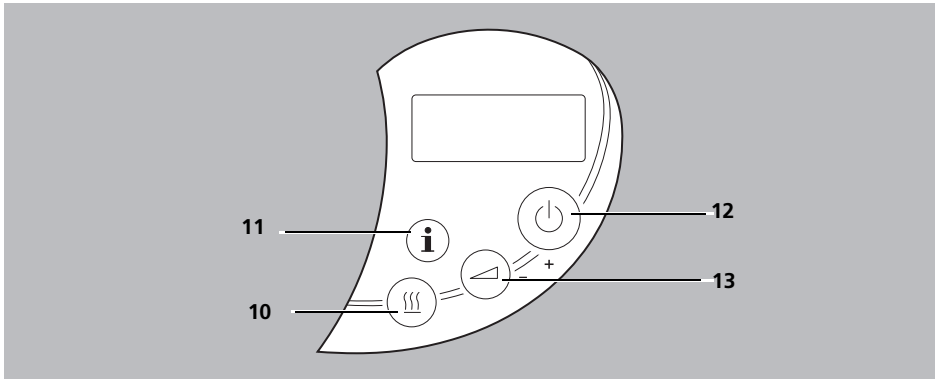

No.	Name	Description
10	Humidifier key	<ul style="list-style-type: none"> <li>• Activates/deactivates the humidifier.</li> <li>• For scrolling through menus.</li> <li>• When pressed and held, calls up humidifier stage settings during therapy.</li> </ul>
11	Info key	<ul style="list-style-type: none"> <li>• Calls up the Info menu (see "5.2 Info menu" page 37).</li> <li>• Displays current leakage during therapy.</li> <li>• When pressed and held with the device on standby, starts the manual copying process to the SD card.</li> <li>• For exiting menus.</li> </ul>
12	On/off key	<ul style="list-style-type: none"> <li>• Switches the therapy device on and off.</li> <li>• Increases a value in the menu.</li> </ul>
13	Softstart key	<ul style="list-style-type: none"> <li>• Activates/deactivates softstart.</li> <li>• Reduces a value in the menu.</li> <li>• When pressed and held with the device on standby, calls up the patient menu (see "5.1 Patient menu" page 36).</li> <li>• Ends the current mask test prematurely.</li> </ul>

### 3.3 Symbols in the display

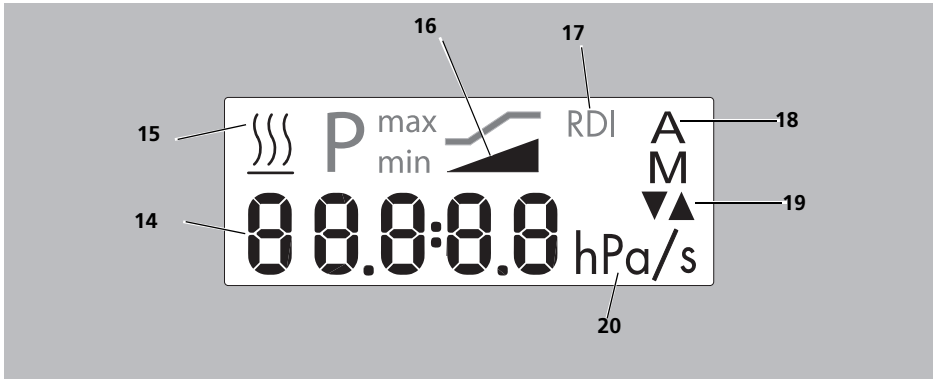

No.	Name	Description
14	Main display	Depending on the symbol, displays various values or parameters.
15	Humidifier symbol	Faded in when the humidifier has been activated. The main display indicates the humidifier stage.
16	Softstart symbol	Faded in when softstart has been activated.
17	RDI	Faded in when the main display is showing respiratory disturbance index (RDI).
18	Auto on/off	<b>A</b> (Automatic) is faded in when Auto on/off is activated. <b>M</b> (Manual) is faded in when Auto on/off is deactivated.
19	Arrows	The up arrow flashes as pressure rises. The down arrow flashes as pressure drops. Both arrows are faded in when exhalation relief is activated. If the SD card is accessed, the arrows indicate whether the card is being read from or written to.
20	hPa	Faded in when the main display is showing therapy pressure.



### 3.4 Components

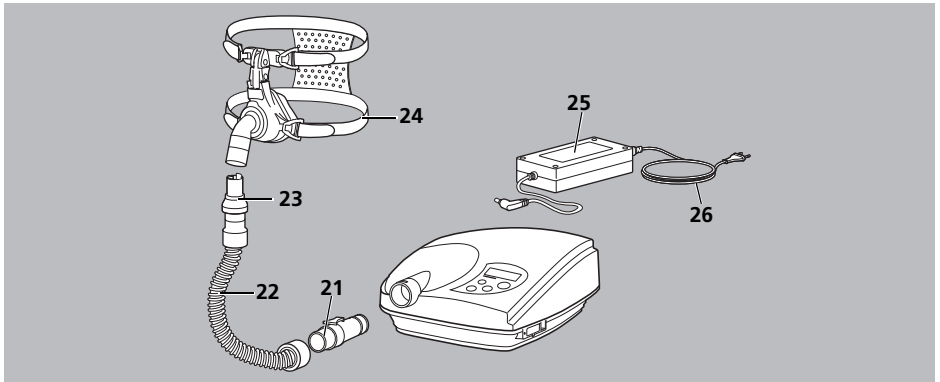

No.	Name	Description
21	Adapter	Connects the breathing tube to the therapy device.
22	Breathing tube	Connects the therapy device to the breathing mask.
23	Exhalation system (optional)	If your mask has no integrated exhalation system, this is where exhaled air escapes during therapy.
24	Breathing mask	Supplies the patient with respiratory air.
25	Power supply unit	Supplies the therapy device with power.
26	Power cord	Connects the power supply unit to the socket.

### 3.5 Accessories

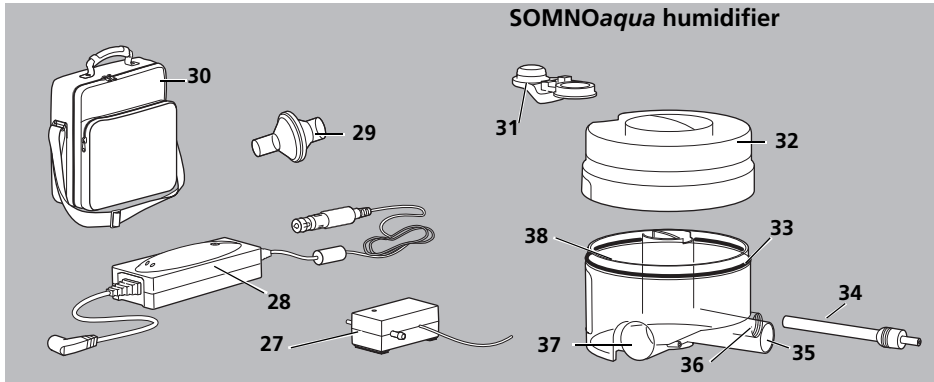



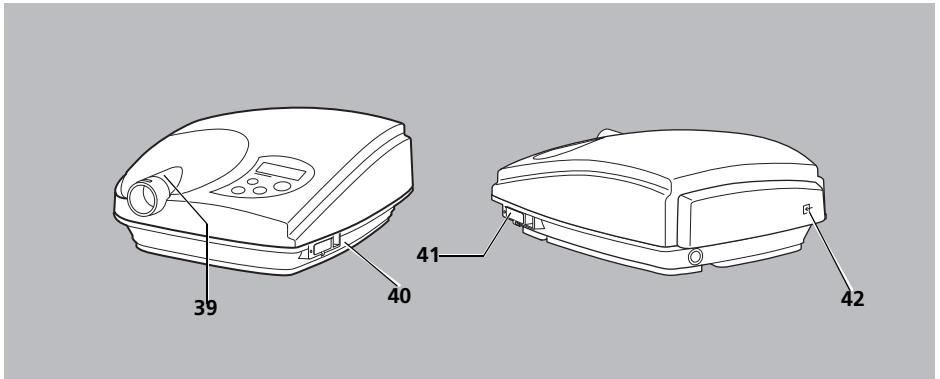

No.	Name	Description
27	O <sub>2</sub> supply valve	Supplies oxygen to the breathing mask.
28	DC adapter	Can operate the therapy device via a DC socket (12-24 V).
29	Bacteria filter	Protects the patient from bacteria when the therapy device is used by several patients.
30	Carrying bag	Protects the therapy device when it is being transported.
<b>SOMNOaqua humidifier</b>		
31	Sealing plug	Seals the filling opening of the humidifier.
32	Top part of housing	Seals the humidifier.
33	Seal	Prevents water running out.
34	Heater rod	Heats the water in the humidifier.
35	Inlet connector	Connects the therapy device to the humidifier.
36	Pressure measuring connector	For measuring current therapy pressure.
37	Outlet connector	Connects the humidifier to the breathing tube.
38	Lower part of housing	Contains the water for humidifying respiratory air.

## 3.6 Markings

### 3.6.1 Markings on the therapy device



No.	Symbol	Meaning
39		Device outlet port: outlet for ambient air
40		Please refer to the instructions for use.
41		Slot for the SD card
42		Filter compartment lid: inlet for ambient air at room temperature

### 3.6.2 Markings on the humidifier

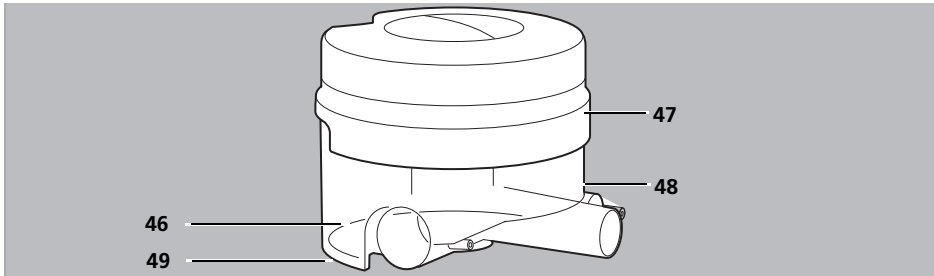



No.	Symbol	Meaning
46		Do not use the humidifier on patients whose airways have been bypassed.
47		Device is heated. Do not touch heater rod.
48	SN	Serial number of humidifier
<b>Underside</b>		
49		Degree of protection against electric shock: device type BF
		Do not dispose of the device in domestic waste
		Year of manufacture
	<b>CE 0197</b>	CE symbol (confirms that the product conforms to the applicable European directives)
	<b>24 V DC</b>	24 V DC

### 3.6.3 Markings on the device ID plate

Symbol	Meaning
	Year of manufacture
	Degree of protection against electric shock: device type BF
	Do not dispose of the device in domestic waste
	Follow the relevant instructions for use

Symbol	Meaning
SN	Serial number of the therapy device
	Type of protection against electric shock: device of protection class II

### 3.6.4 Labeling on the packaging of the therapy device

Symbol	Meaning
	Permitted temperature for storage: -40 °C to 70 °C
	Permitted humidity for storage: maximum 95 % relative humidity

### 3.6.5 Labeling on the packaging of the breathing tube

Symbol	Meaning
	Use only for a single patient.

## 4 Operation

### 4.1 Set up device

#### NOTICE

#### Material damage from overheating!

Excessive temperatures may lead to the therapy device overheating and damage the therapy device.

- ⇒ Do not cover therapy device and power supply unit with textiles (e.g. the blanket).
- ⇒ Do not operate device in the vicinity of a radiator.
- ⇒ Do not expose device to direct sunlight.

1. Place device on a level surface.

### 4.2 Connect components

#### 4.2.1 Connect power supply

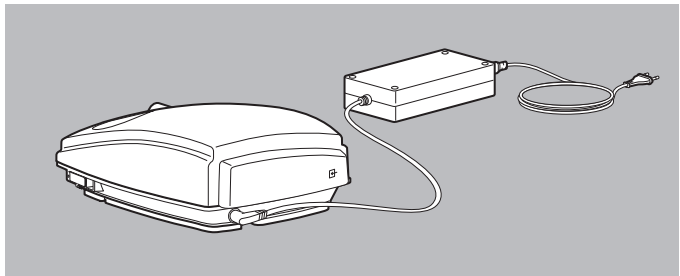

1. Plug connecting cable for power supply unit into power socket on the therapy device.



If you want to operate the therapy device at 12 V or 24 V, connect the optional DC adapter WM 24469 instead of the power supply unit.

2. Plug the power cord into the socket.  
The power supply unit automatically adapts to the voltage (115 V - 230 V).

*Result* The power supply is connected. The device switches to standby.  appears in the display. Depending on the setting, other symbols may appear in the display (see "3.3 Symbols in the display" page 16).

## 4.2.2 Connect breathing tube

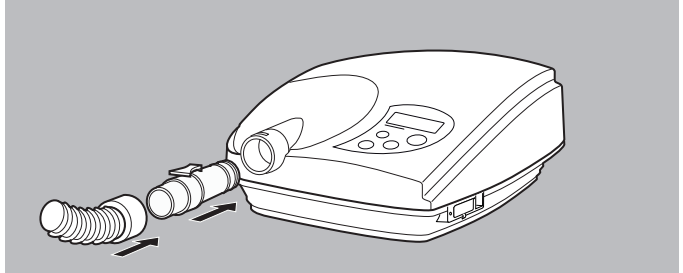

1. Plug adapter onto device outlet port.

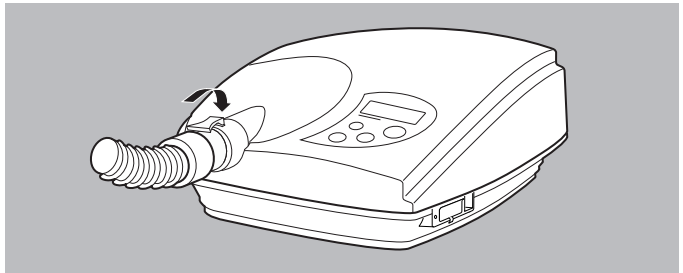

2. Plug breathing tube onto the adapter. In the process, please note: the latch must engage audibly.

*Result* The breathing tube is connected.

## 4.2.3 Connect breathing mask

1. Follow the instructions for use for the breathing mask.
2. If present: adjust the forehead cushion of the breathing mask.
3. Connect the head strap to the mask.

**CAUTION**

**Risk of suffocation if exhalation system missing!**

If full-face masks without an integrated emergency exhalation system are used, the CO<sub>2</sub> concentration may rise to critical values and put the patient at risk.

⇒ Always use an external exhalation system.

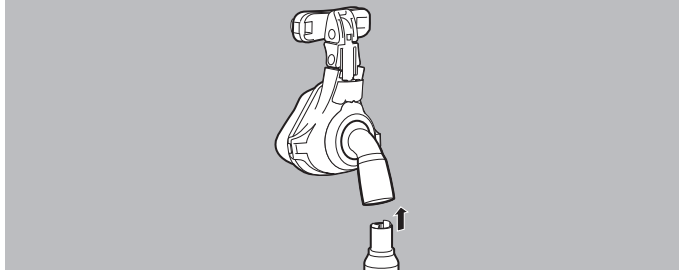

4. If not integrated: connect the external exhalation system between the breathing mask and the breathing tube.
5. Put on the mask.

**CAUTION**

**Risk of injury if breathing tube routed incorrectly!**

An incorrectly routed breathing tube may injure the patient.

⇒ Never wrap the breathing tube around the neck.

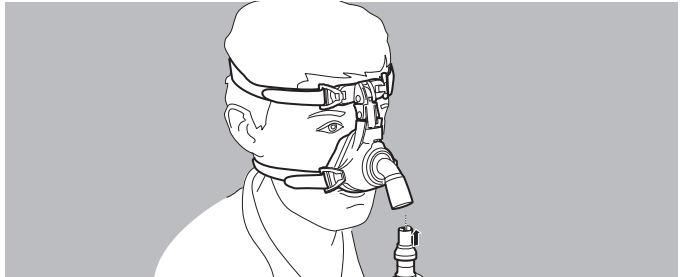

6. Connect the mask to the breathing tube.
7. If necessary: perform a mask test (see "4.4.3 Perform a mask test" page 30).

*Result* The breathing mask is connected.



## 4.3 Connect accessories

### 4.3.1 Connect humidifier

#### Fill humidifier

#### NOTICE

#### Material damage from overfilling!

- Escaping water may run into the therapy device and damage it.
- ⇒ Take the humidifier off the therapy device before filling it.
  - ⇒ Only fill the humidifier up to the "max." mark.

1. If necessary: take the humidifier off the therapy device (see "Remove humidifier" page 27).

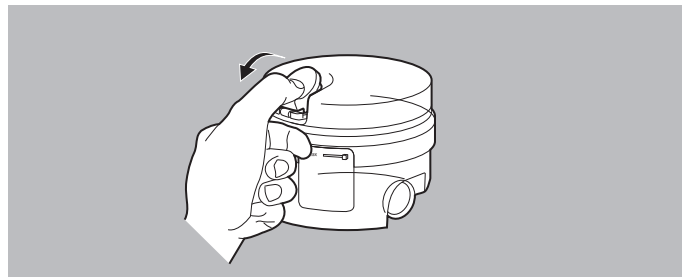

2. Open the sealing plug.

#### NOTICE

#### Material damage from hot water and aromatic additives!

Hot water or aromatic additives (such as eucalyptus oil) may damage the housing of the respiratory air humidifier and the heater rod.

- ⇒ Fill only with cold or warm water.
- ⇒ Do not use any aromatic additives.

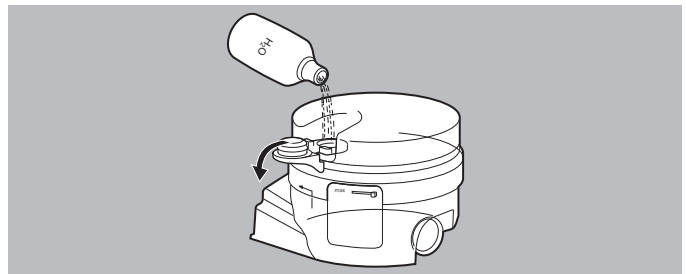

3. Fill the humidifier up to the "max." mark with cold distilled water.



In exceptional cases, you can also use boiled water with a low lime content, but in this case, note that you will have to de-scale the humidifier more often (see "6.4.1 Descale the humidifier" page 47).

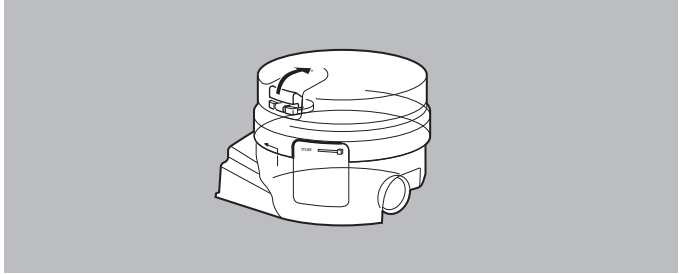

4. Close humidifier.
5. Test for leaks. To do this, stroke a finger over the underside or place the humidifier on a cloth.

*Result* The humidifier is full.

### **Fit humidifier**

1. If necessary: remove breathing tube from therapy device.

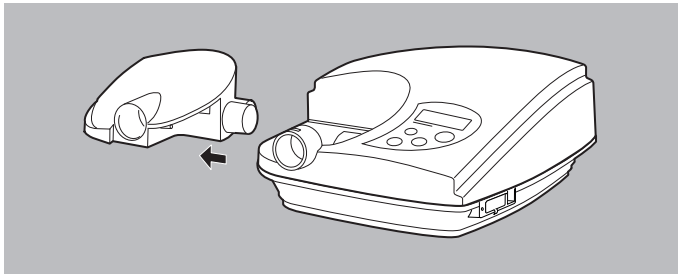

2. Take the cover off the side of the therapy device.
3. Fill humidifier.

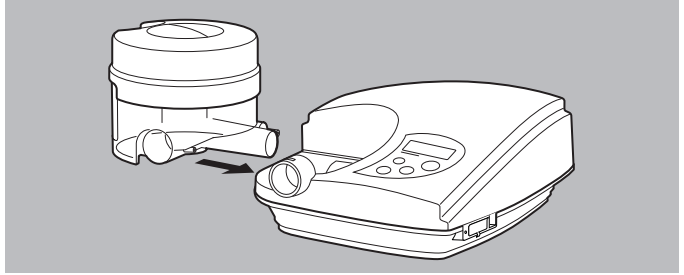

4. Push the humidifier into the locator for it on the side.

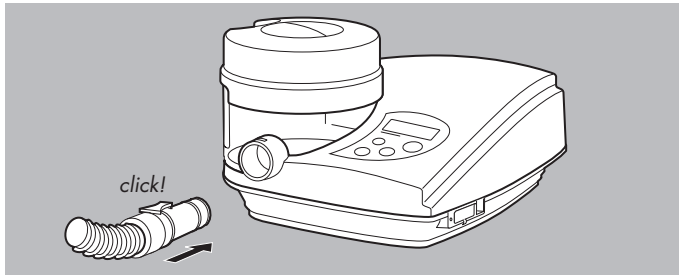

5. Reconnect breathing tube.

*Result* The humidifier is fitted.

### Remove humidifier

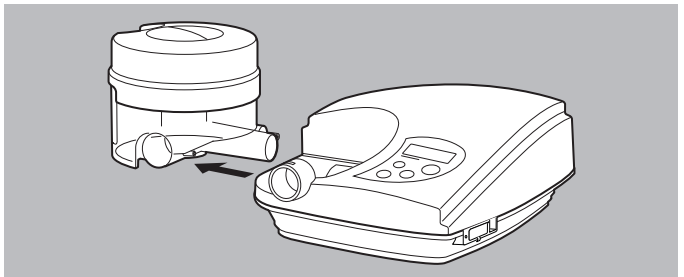

1. Push the humidifier sideways out of its locator.

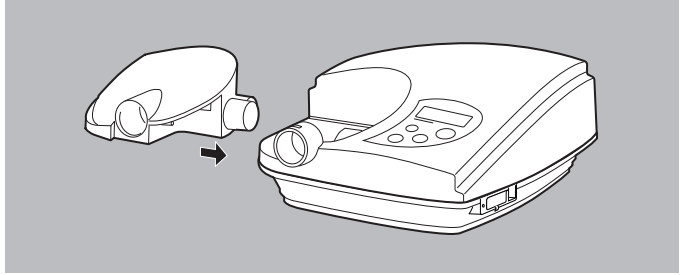

2. Push the cap into the locator for the humidifier up to the stop.
3. Connect breathing tube (see "4.2.2 Connect breathing tube" page 23).

*Result* Humidifier is removed.

### 4.3.2 Connect bacteria filter

1. Connect the bacteria filter between the breathing tube and the adapter.
2. Test pressure.



If you use a bacteria filter, pressure consistency and flow rate may drop.

### 4.3.3 Connect oxygen supply valve



#### **Risk of injury from burning oxygen!**

Supplying oxygen without a special safety device can lead to fire and injure people.

- ⇒ Always use an oxygen supply valve.
- ⇒ Follow the instructions on handling oxygen.
- ⇒ Follow the instructions for use for the oxygen supply valve and the oxygen device.

1. Connect the oxygen supply valve according to its instructions for use.

## 4.4 Operate therapy device

### 4.4.1 Switch on therapy device

1. Connect components (see "4.2 Connect components" page 22).  
The device switches to standby.
2. Press on/off key  to switch on the therapy device.  
**Alternatively,**  
if auto on/off is activated: breathe into the mask.

*Result* The therapy device starts pumping air through the breathing tube. Total therapy time appears in the display for 3 seconds. Depending on the settings, the following may happen:

- current therapy pressure appears in the display. Therapy starts. Other symbols may be displayed (see "3.3 Symbols in the display" page 16).
- the mask test runs. Mask test pressure appears in the display for 30 seconds.



- Softstart is activated. Time and pressure value appear alternately in the display.



## 4.4.2 Switch off therapy device

*Condition* Therapy device is switched on.

1. Press on/off key  to switch off the therapy device.

**Alternatively,**

if auto on/off is activated: remove mask.

Daily therapy time appears in the display.

*Result* Therapy device is switched off and switches to standby.



- If you keep the on/off key pressed when switching off, the device will indicate operating hours.
- To save energy, you can disconnect the plug from the socket during the day. **Always** switch off the device at the on/off switch first. Wait until the LED on the SD card slot has gone out before disconnecting the plug from the socket or interrupting the power supply via a switchable multiple socket.

## 4.4.3 Perform a mask test

*Condition* The mask test is activated.



1. Switch on the therapy device.  
Mask test pressure is shown in the display.
2. Check mask for leaks.
3. If necessary, adapt the mask straps.
4. Wait until the therapy device ends the mask test automatically (about 30 seconds).  
**Alternatively, press the** softstart key  to cancel the mask test.

*Result* Mask test is performed.

## 4.5 Transport therapy device

*Condition* Carrying bag is clean.

1. Pack the therapy device in the carrying bag.
2. Pack components and accessories in the carrying bag.
3. Pack the instructions for use in the carrying bag.

*Result* Therapy device is ready for transport.

## 4.6 Handling the SD card

### NOTICE

#### **Loss of data as a result of incorrect SD card!**

Functionality may be restricted or data may be lost in the case of SD cards not ordered through Weinmann.

- ⇒ Use only branded SD cards. Recommended: order SD card through Weinmann.
- ⇒ Do not use SD card for third-party files.



An SD card is not essential for operating the therapy device. Therapy data and settings are also stored inside the therapy device.

### 4.6.1 Remove SD card

*Condition* Therapy device on standby.

1. Open cover of SD card slot.

### NOTICE

#### **Loss of data due to incorrect handling!**

If you remove the SD card whilst the red LED is on, data may be lost.

- ⇒ Only push on the SD card when the red LED is not on.
2. Push the SD card briefly.  
The SD card comes out a little way.

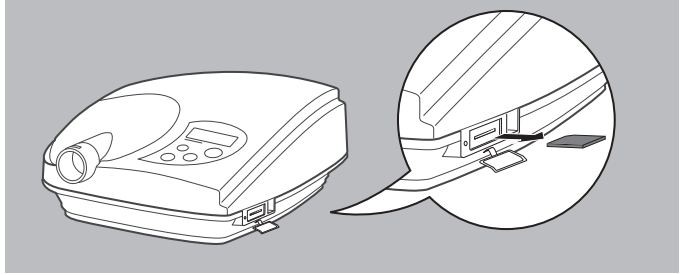

3. Remove SD card.
4. Close cover of SD card slot.

*Result* The SD card is no longer in the therapy device.

#### 4.6.2 Insert SD card

*Condition* Therapy device on standby.

1. Open cover of SD card slot.

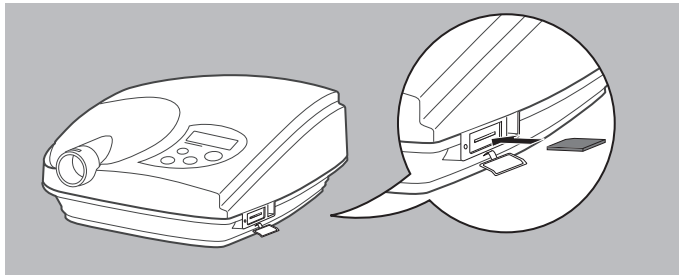

2. Push SD card into SD card slot until it engages. In the process, please note: the missing corner of the SD card must face front right when you push in the card.
3. Close SD card cover.

*Result* The SD card is operational in the therapy device. The symbol  $\epsilon$  appears in the display.



### 4.6.3 Save therapy data on the SD card

#### NOTICE

#### Loss of data as a result of power failure!

If the therapy device is disconnected from the power supply during the save process, therapy data may be lost.

⇒ Leave the therapy device connected to the power supply during the save process.

#### Automatic save

The therapy device saves therapy data automatically in the cases below.

- Whenever you switch off the therapy device. The condition is that therapy lasted longer than 6 minutes.
- Whenever you put in a new SD card with the device on standby.
- Following an interruption in saving, when you connect the therapy device to the power supply.

During the save process, the SD card symbol flashes in the display and remaining time is displayed. The device then switches to the default display



#### Save therapy data manually



If you save therapy data manually, a larger amount of data is saved once. It is only necessary to save therapy data manually if your doctor or specialist dealer has asked you to do this. Only save therapy data manually shortly before removing the SD card to check therapy data. The manually-generated save will be overwritten by the next automatic save.

*Condition* Therapy device on standby.

1. Keep the Info key  depressed for longer than 3 seconds.
  - The red LED comes on.

- The SD card symbol flashes in the display and remaining time is displayed. The device then switches to the default display



*Result* Therapy data are saved on the SD card. The data saved depend on the settings your doctor has made.

#### 4.6.4 Configure therapy device using the SD card

*Condition* Therapy device on standby.



You can configure not only your therapy device but a replacement device using your SD card.

If a replacement device is involved, **Card** appears in the display.

1. Insert SD card.

- The therapy device adopts the settings from the SD card. As long as the process is running, the arrow in the display flashes and the LED is on.



- The SD card saves the therapy data from the therapy device.
- If configuration was successful, **CONF**  appears in the display.



2. Press any key to return to the default display.

*Result* The therapy device has adopted the settings from the SD card.

### 4.6.5 Use the therapy journal on a PC

1. Remove SD card (see "4.6.1 Remove SD card" page 31).
2. Connect SD card to PC:
  - via the SD card slot on the PCor
  - via an external card reader connected to the PC.
3. Transfer the csv file stored on the SD card to the PC (see "Therapy journal" page 7).

*Result* 4. The therapy data from the SD card can be used on the PC.

### 4.6.6 Send away SD card

1. Remove SD card (see "4.6.1 Remove SD card" page 31).
2. Mark the SD card with your name and date of birth to prevent confusion when it reaches the doctor or specialist dealer.



SD cards ordered from Weinmann have a field for this which you can write on.

3. Put the SD card in the dispatch bag included in the scope of supply.
4. Send the SD card to the doctor or specialist dealer.

# 5 Settings

## 5.1 Patient menu







### 5.1.1 Adjustable parameters

You can set the following parameters in the patient menu if your doctor has enabled them for you.

Parameter	Description	Display on screen	Value range
Exhalation relief (softPAP)	The therapy device temporarily reduces therapy pressure before the transition to exhalation.	50Ft	□ (softPAP off) † (softPAP gentle) ‡ (softPAP normal)
Mask test	The therapy device outputs a higher pressure for 30 seconds after being switched on. This makes it easier for you to detect leaks at the mask (see "4.4.3 Perform a mask test" page 30).	£:	□ (Mask test deactivated) 8 (Pressure 8 hPa) † (Pressure 10 hPa) ‡ (Pressure 12 hPa) †4 (Pressure 14 hPa)
Auto on/off	The therapy device can be switched on by a breath (> 0.5 hPa) being taken into the mask and switches off automatically after 5 seconds without a breath being taken. Exception: in full-face masks with an integrated exhalation system, the therapy device does not detect the change in pressure, so it does not react.	<b>M</b> <b>A</b>	<b>M</b> (Manual/deactivated) <b>A</b> (Automatic/activated)

## 5.1.2 Navigate in the patient menu



*Condition* Therapy device is on standby.



1. Keep the softstart key  depressed until the patient menu opens.  
The current exhalation relief setting (**SoFt**) flashes in the display.
2. Release the softstart key .
3. Press humidifier key  to scroll in the patient menu.
4. Press the on/off key  to increase a value.
5. Press the softstart key  to decrease a value.
6. Press the info key  briefly to exit the patient menu.  
**Alternatively,**  
do not press any key for 15 seconds.  
The device switches back to standby.

## 5.2 Info menu

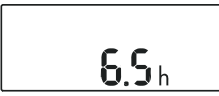
### 5.2.1 Parameters which can be displayed





You can have additional settings, enabled for you by your doctor, displayed in the Info menu. A variety of parameters will appear depending on whether the therapy device is on standby or switched on.

Display	Meaning
	(Mean) therapy time
	Mean RDI
	Mean obstructive RDI

Display	Meaning
	Mean central RDI
	Percentage proportion of therapy time at an impermissibly high leakage rate
	90% pressure percentile

## 5.2.2 Navigate in the Info menu (standby)

*Condition* Therapy device on standby.

1. Briefly press the info key .  
Therapy time and the current date flash alternately.
2. Press the humidifier key  briefly to scroll in the Info menu.  
The parameters enabled by the doctor appear.
3. Press the softstart key  (-) or the on/off key  (+) to call up the data of a different day or a different period:

Display	Meaning
2302.	Display a specific date in the past 6 days.
7 d	Mean value for the last 7 days.
14 d	Mean value for the last 14 days.
30 d	Mean value for the last 30 days.
180 d	Mean value for the last 180 days.
366 d	Mean value for the last 366 days.

4. Wait about 10 seconds to exit the Info menu.  
The therapy device switches back to standby or the therapy display.



- Data are displayed only if they are actually present in the therapy device. Example: if data for only 34 days are present in the device, then after 30 d the device shows 34 d directly and then no more data.
- Each therapy day begins and ends at 12 noon. Data recorded from midnight to 12 noon are assigned to the previous calendar day.

### 5.2.3 Display leaks (operation)

*Condition* Therapy device switched on.

1. Briefly press the info key .

*Result* The leakage display appears:

Display	Meaning
	No leakage/low leakage: mask is in optimum position.
	Moderate leakage: mask is not in optimum position, quality of therapy may be restricted. Adjust mask.
	High leakage: effective therapy is no longer possible. Adjust mask.

## 5.3 Set softstart

### 5.3.1 Set softstart time



*Condition* Therapy device is switched on. Softstart is activated by doctor.

1. Keep the softstart key depressed.  
The current setting for softstart time flashes in the display.
2. Press the on/off key to increase the value.
3. Press the softstart key to reduce the value.
4. Wait 3 seconds to save the setting.

*Result* Softstart time is set. The setting is retained even when you turn off the device.

### 5.3.2 Switch softstart on and off



*Condition* Therapy device is switched on. Softstart is activated by doctor.

1. Briefly press the softstart key  to switch on softstart.  
Remaining time and therapy pressure flash alternately.
2. Press the softstart key  briefly to switch off softstart.

## 5.4 Set humidifier

Value	Display on screen	Value range
Heating stage		1 (Lowest heating setting) 2 3 4 5 6 (Highest heating setting)

### 5.4.1 Set humidifier stage

- Condition*
- Humidifier is connected (see "4.3.1 Connect humidifier" page 25).
  - Therapy device is switched on.
1. Press and hold the humidifier key .  
The humidifier symbol and humidifier stage set flash in the display.
  2. Press the on/off key  to increase the heating stage.
  3. Press the softstart key  to reduce the heating stage.







The setting suitable for you depends on room temperature and humidity. Heating stage 3 is a default setting. If you have dry airways in the morning, heating output is set too low. If condensation has formed in the breathing tube in the morning, heating output is set too high.

4. Wait 3 seconds to save the setting.  
The therapy device switches back to the default display.

*Result* The heating stage is set.

## 5.4.2 Switch humidifier on and off

*Condition*

- Humidifier is connected (see "4.3.1 Connect humidifier" page 25).
  - Therapy device is switched on.
1. Briefly press the humidifier key  to switch on the humidifier. The set humidifier stage and the humidifier symbol appear in the display.
  2. Press humidifier key  briefly to switch off the humidifier. The humidifier symbol goes out. The therapy device remains switched on.



When the water level in the humidifier is too low, the therapy device switches off the humidifier automatically.

# 6 Hygiene treatment

## 6.1 General information

- Follow the instructions for the hygiene treatment of the accessories in the respective instructions for use.
- **This product may contain disposable items.** Disposable items are intended to be used only once, so use these items only once and do **not** reprocess them. Reprocessing disposable items may impair the functionality and safety of the product and lead to unforeseeable reactions due to ageing, embrittlement, wear, thermal load, the effects of chemical processes etc..
- Use suitable gloves (e.g. household or disposable gloves) when disinfecting.
- Follow the instructions for use for the disinfectant used.
- Recommended: terralin® protect for disinfecting by wiping and gigasept FF® for disinfecting by immersion.

## 6.2 Intervals

Interval	Action
Daily	Clean breathing mask (see instructions for use for breathing mask).
	Clean humidifier (see "6.4 Hygiene treatment for humidifier" page 46).
Weekly	Clean coarse dust filter (see "6.3.1 Clean coarse dust filter" page 44).
	Check fine filter. Replace if necessary (see "6.3.2 Replace fine filter" page 45).
	Check breathing tube. Clean if necessary (see "6.5 Hygiene treatment for breathing tube" page 49).
	Clean housing of therapy device (see "6.3 Hygiene treatment for therapy device" page 44).
	Wash the headgear of the mask (see instructions for use for the breathing mask).
Monthly	Replace fine filter (see "6.3.2 Replace fine filter" page 45).
	Clean breathing tube (see "6.5 Hygiene treatment for breathing tube" page 49).
Every 6 months	Replace coarse dust filter (see "9 Storage and disposal" page 54).
Every 12 months	Replace breathing mask.
	Replace breathing tube.
Every 2 years	Replace the housing parts of the humidifier.
Only if required	Descale the humidifier (see "6.4 Hygiene treatment for humidifier" page 46).
	Disinfect therapy device (see "6.3 Hygiene treatment for therapy device" page 44).
	Disinfect humidifier (see "6.4 Hygiene treatment for humidifier" page 46).
On change of patient	Replace SD card. If the therapy device or humidifier have been used without a bacteria filter: have a professional hygiene treatment performed. Send therapy device to specialist dealer.

## 6.3 Hygiene treatment for therapy device

### CAUTION

#### **Risk of injury from electric shock!**

Penetration of fluids may lead to a short circuit, injure the user and damage the therapy device.

- ⇒ Disconnect the therapy device from the power supply before the hygiene treatment.
  - ⇒ Do not immerse the therapy device or its components in liquids.
  - ⇒ Do not pour liquids over the therapy device or its components.
  - ⇒ Keep liquid away from the pressure measurement connector.
1. Remove humidifier (see "4.3.1 Connect humidifier" page 25).
  2. Subject the therapy device and its components to a hygiene treatment in accordance with the table below.

Part	Cleaning	Disinfecting	Sterilizing
Housing	Wipe with a damp cloth.	Disinfect by wiping	Not permitted
Power supply unit	Wipe with a damp cloth.	Disinfect by wiping	Not permitted
Power cord	Wipe with a damp cloth.	Disinfect by wiping	Not permitted

3. Perform a function check.

*Result* Therapy device and components have been subjected to a hygiene treatment.

### 6.3.1 Clean coarse dust filter

*Condition* Therapy device disconnected from power supply.

1. Remove filter compartment lid.

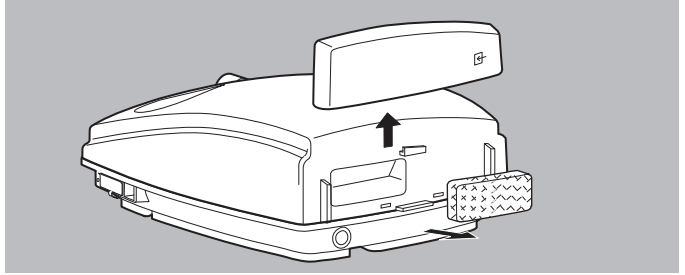

2. Remove coarse dust filter.
3. Clean coarse dust filter under running water.
4. Allow coarse dust filter to dry.
5. Insert coarse dust filter in the bracket.
6. Close filter compartment lid.

*Result* The coarse dust filter is clean.

### 6.3.2 Replace fine filter

*Condition* Therapy device disconnected from power supply.

1. Remove filter compartment lid.
2. Remove coarse dust filter.

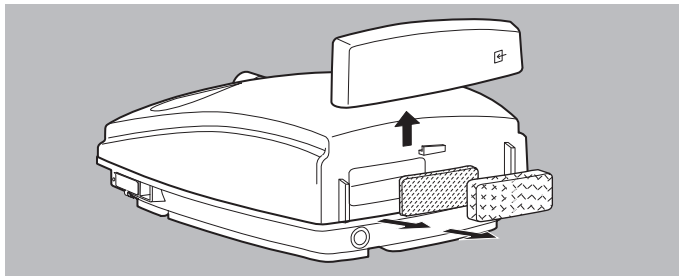

3. Remove fine filter.
4. Insert new fine filter in the bracket.
5. Insert coarse dust filter in the bracket.
6. Close filter compartment lid.

*Result* Fine filter is replaced.

## 6.4 Hygiene treatment for humidifier

### CAUTION

#### Risk of injury from hot heater rod!

After operation, the heater rod of the humidifier is hot and touching it can result in burns.

- ⇒ Allow the heater rod to cool down completely.
- ⇒ Avoid contact with the heater rod.

*Condition* Humidifier taken off the therapy device.

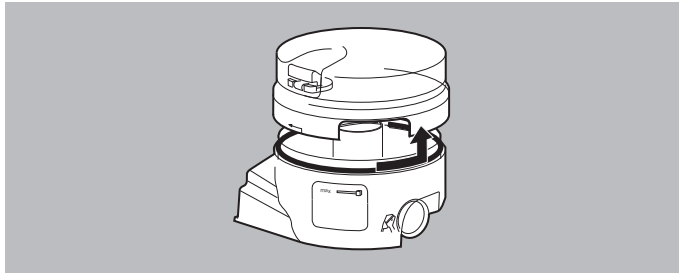

1. To open the humidifier, turn it counterclockwise.
2. Take off top part of housing.

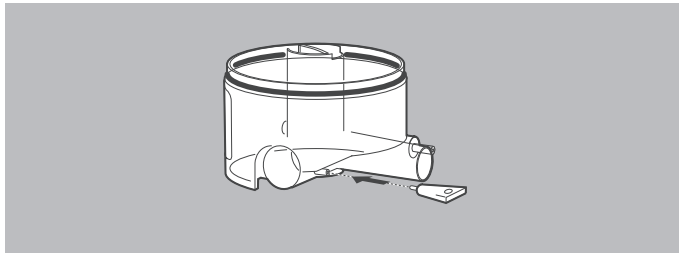

3. Subject the parts of the housing to a hygiene treatment in accordance with the table below.

Part	Cleaning	Disinfecting	Sterilizing
Housing	With hot water and detergent*. If necessary: descale (see below).	Disinfect by immersion	Not permitted
Heater rod	If necessary: descale (see below).	Disinfect by immersion	Not permitted

- \* Recommended: wash the parts of the housing weekly in the top basket of the dishwasher (maximum 65 °C).
- 4. Rinse the parts of the housing with clean water.
- 5. Shake out the parts of the housing thoroughly.
- 6. Dry the parts with a soft cloth. In the process, please note: the heater rod contact must be dry.

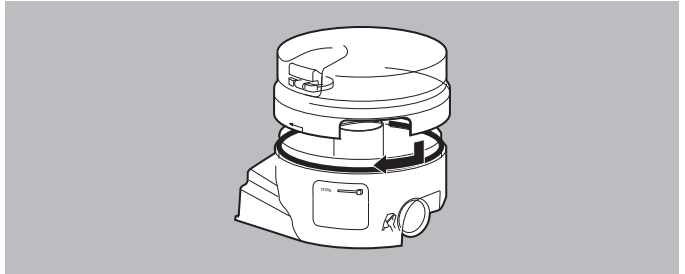

- 7. Screw together the parts of the housing.

*Result* The humidifier has been subjected to a hygiene treatment.

### 6.4.1 Descale the humidifier

- 1. Pour 150 ml pure household vinegar (5 % solution without additives) into the lower part of the housing.
- 2. Leave vinegar to take effect for 1 hour.
- 3. Rinse off the lower part of the housing and the heater rod with clean water.
- 4. Dry lower part of housing and heater rod.

*Result* Lower part of housing and heater rod have been descaled.

### 6.4.2 Replace seals

#### Replace heater rod seal

*Condition* Humidifier taken off the therapy device and emptied.

- 1. Open humidifier.

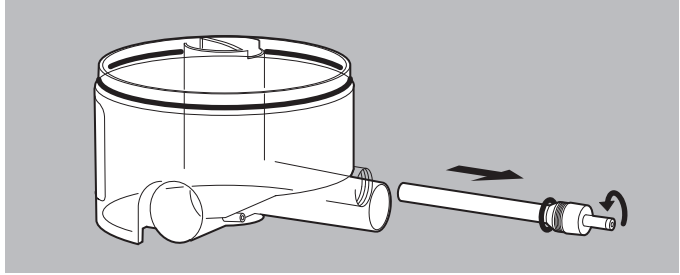

2. Unscrew the heater rod from the lower part of the housing.

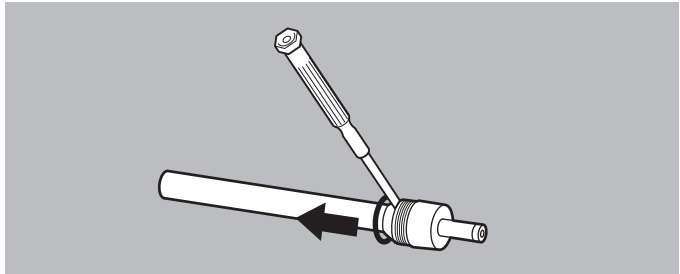

3. Use a screwdriver to remove the seal carefully without damaging the groove.

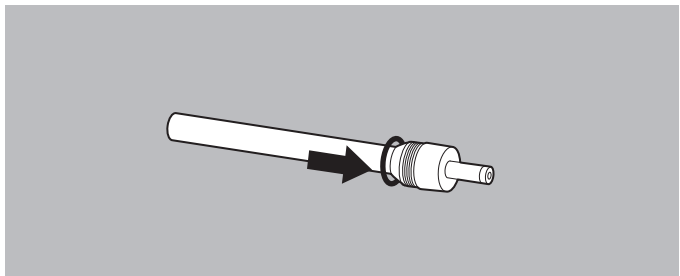

4. Push a new seal into the groove for the heater rod.
5. Screw the heater rod into the lower part of the housing.
6. Close humidifier.

*Result* The heater rod seal has been replaced.

### **Replace seal for lower part of housing**

*Condition* Humidifier taken off the therapy device and emptied.

1. Open humidifier.



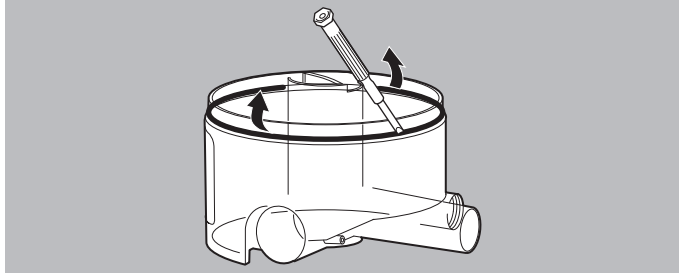

2. Use a screwdriver to remove the seal carefully without damaging the groove.

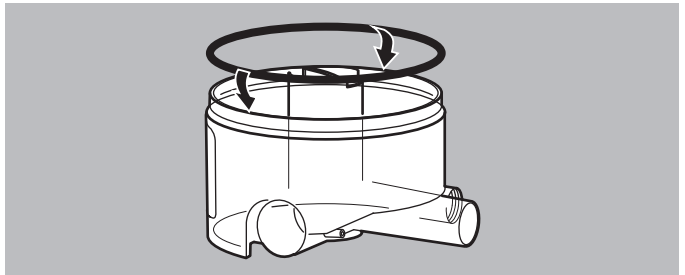

3. Push a new seal into the groove for the lower part of the housing.
4. Close humidifier.

*Result* The seal for the lower part of the housing has been replaced.

## 6.5 Hygiene treatment for breathing tube

### NOTICE

#### **Risk of material damage as a result of ingress of liquids!**

Liquids which penetrate the therapy device may damage it.  
 ⇒ Use the breathing tube only when completely dry.

1. Take breathing tube and adapter off the therapy device.
2. Take the adapter off the breathing tube.

3. Subject the breathing tube and adapter to a hygiene treatment in accordance with the table below.



<b>Part</b>	<b>Cleaning</b>	<b>Disinfecting</b>	<b>Sterilizing</b>
Breathing tube	With hot water and detergent.	Disinfect by immersion	Not permitted
Adapter	With hot water and detergent.	Disinfect by immersion	Not permitted

4. Rinse off the breathing tube and adapter with clean water.
5. Shake out the breathing tube thoroughly.
6. Hang up the breathing tube and leave it to drip.
7. Dry breathing tube.

*Result* Breathing tube has been subjected to hygiene treatment.

### **Dry breathing tube**

*Condition* Therapy device on standby.

1. If necessary: remove humidifier (see "4.3.1 Connect humidifier" page 25).
2. Connect breathing tube (see "4.2.2 Connect breathing tube" page 23).
3. Press the on/off key  and the softstart key simultaneously. The therapy device starts pumping air through the breathing tube. The remaining time is displayed.
4. Wait until the drying process is ended. The therapy device switches off automatically.  
**Alternatively,**  
to end the drying process: press the on/off key .
5. If tube is not completely dry, repeat the drying process.

*Result* Breathing tube is dry.



# 7 Function check

## 7.1 Intervals

Perform a function check every 6 months.

## 7.2 Check therapy device

*Condition* Therapy device connected and on standby.

1. Switch on therapy device.
2. If mask test is active: press softstart key  to cancel the mask test.
3. If softstart is active: press the softstart key  to cancel softstart.  
The device operates.
4. Close the opening on the mask, with a knee, for example.
5. Compare the pressure shown in the display with the prescribed pressure.
6. Switch off therapy device.
7. If pressure deviation is >1 hPa: contact your specialist dealer.

*Result* Function check is performed.

## 7.3 Check humidifier

1. Check housing for cracks, damage and severe soiling.
2. If there are cracks, damage or soiling: replace plastic parts or seals.
3. Fill humidifier with water up to the mark (see "4.3.1 Connect humidifier" page 25).
4. Check whether the humidifier has any leaks.
5. If the humidifier leaks: replace seals (see "6.4.2 Replace seals" page 47).

6. Pour out water.
7. Fill humidifier with 50 ml water.
8. Connect humidifier to therapy device.
9. Switch on therapy device.
10. Press humidifier key to switch on humidifier.
11. Set heating stage 6 on the therapy device (see "5.4 Set humidifier" page 40).
12. Check whether the humidifier is heating up.
13. If the humidifier does not heat up after 15 minutes: contact your specialist dealer or send the therapy device and humidifier back to the manufacturer.

*Result* Function check for humidifier has been performed.

# 8 Servicing

## 8.1 Intervals

The device is designed for a service life of 5 years.

When used in accordance with purpose and in accordance with the instructions for use, the device requires no maintenance during this period.

# 9 Storage and disposal

## 9.1 Storage

### 9.1.1 General information

- Observe the permitted ambient conditions (see "11.1 Technical data" page 58).

### 9.1.2 Store therapy device

1. Disconnect therapy device from the power supply.
2. Clean therapy device and accessories (see "6 Hygiene treatment" page 42).
3. Store therapy device and accessories in a dry place.

## 9.2 Disposal

### 9.2.1 Therapy device and accessories



Do not dispose of the therapy device in domestic waste. To dispose of the therapy device properly, contact an approved, certified electronics scrap dealer. You can obtain the address from your Environment Officer or your local authority.

### 9.2.2 Packaging

The device packaging (cardboard and inserts) can be disposed of in paper recycling facilities.

# 10 Faults and display messages

## 10.1 Faults

<b>Fault</b>	<b>Cause of fault</b>	<b>Remedy</b>
No running noise, nothing in the display.	No power supply.	Check power cord firmly connected. Check function of socket.
Therapy device cannot be switched on by a breath being taken into it.	Auto on/off not activated.	Activate auto on/off (see "5.1.1 Adjustable parameters" page 36).
Setting for exhalation relief cannot be changed.	Setting is disabled.	Clarify with the doctor whether the setting can be changed for your therapy or whether the option of making a setting can be enabled.
Softstart cannot be switched on.	The softstart function is disabled.	Clarify with your doctor whether the softstart function can be enabled for your therapy.
Therapy device does not switch off after approx. 5 seconds once mask is removed.	Auto on/off not activated.	Activate auto on/off (see "5.1.1 Adjustable parameters" page 36).
Therapy device is running, but does not reach the lower pressure limit.	Filters dirty.	Clean filters. Replace if necessary (see "6.3 Hygiene treatment for therapy device" page 44).
	Mask leaking.	Adjust headgear so that the mask is tight. If necessary, replace defective mask.
Message <b>Err 10</b> , <b>Err 20</b> , <b>Err 30</b> ... <b>Err 80</b> in display.	Electronics problems.	Disconnect the therapy device from the power supply and reconnect it. If the error is still being displayed, the therapy device must be repaired by Weinmann or an authorized specialist dealer as soon as possible.
Therapy journal is not shown in different columns on the computer.	Incorrect settings in your computer's operating system.	Under the "Region" options of the operating system, set the list separator to a semicolon.

## 10.2 Display messages

Display messages are error messages which may occur in communication between the therapy device and the SD card. These messages do not impair the function of the therapy device. Configuration faults are displayed until the next successful configuration in the display. The other display messages can be removed from the display by pressing any key. In this case, however, the functions of the SD card may then be impaired.

Process code	Cause	Remedy
Message <b>C0nF 1</b> in display	Configuration file on SD card is defective.	Have physician or specialist dealer write parameters to the SD card again.
Message <b>C0nF2</b> in display	SD card is full.	Clear data from the SD card or have data cleared by physician or specialist dealer.
Message <b>C0nF3</b> in display	Configuration fault: SD card is write-protected.	Remove write-protection from SD card. To do so, switch the switch on the SD card.
Message <b>C0nF4</b> in display	Power failure whilst data being saved.	Remove SD card from the device and put it back in.
Message <b>C0nF5</b> in display	SD card with settings for a different device inserted.	Have physician or specialist dealer load correct device types onto SD card.
Message <b>c 1 0</b> in display	Card contains third-party files and will not be accepted.	If necessary, have SD card reconfigured by physician.
Message <b>c 2 0</b> in display	SD card is full.	Clear data from the SD card or have data cleared by physician or specialist dealer.
Message <b>c 3 0</b> in display	SD card is write-protected.	Remove write-protection from SD card. To do so, switch the switch on the SD card.
Message <b>c 4 0</b> in display	Error during save process.	Save data to SD card again. If the card is defective, request a new SD card from physician or specialist dealer.
Message <b>c 5 0</b> in display	SD card withdrawn during the save process.	Insert SD card again and only remove once the red LED has gone out.
<b>C0nF M</b> (flashing) in display, device cannot be switched on	Master SD card inserted.	Remove SD card. You can use the device without the card. Contact doctor or specialist dealer.
<b>Card</b> flashes in the display	Therapy device is in exchange mode.	Insert the SD card for the previous therapy device.



## 10.3 Humidifier

Fault	Cause of fault	Remedy
Humidifier does not heat up.	Humidifier is not switched on.	Switch on humidifier.
	Electronics defect.	Send the humidifier and the therapy device to the manufacturer, Weinmann, or to an authorized specialist dealer for repair.
The humidifier is leaking.	The heater rod seal is defective.	Replace the seals (see "6.4.2 Replace seals" page 47).
	The seal for the lower part of the housing is defective.	Replace the seals (see "6.4.2 Replace seals" page 47).
	Cracks in lower part.	Replace the lower part.

# 11 Appendix

## 11.1 Technical data

### 11.1.1 Therapy device

	Therapy device	Therapy device with humidifier
Product class to 93/42/EEC	IIa	
Dimensions W x H x D in cm	21 x 9 x 27	21 x 14 x 27
Weight	approx. 1.7 kg	approx. 2.0 kg (excl. water)
<b>Temperature range</b> Operation	+5 °C to +35 °C If the device is operated at +40 °C, the air given off may heat up to as much as 42 °C.	
Storage	-40 °C to +70 °C	
Permitted humidity for operation and storage	≤ 95 % rh (no condensation)	
Air pressure range	700 hPa - 1100 hPa (allows operation at altitudes of up to 2500 m) adapts automatically to altitude	
Diameter of breathing tube connection (mask side)	19,5 mm (fits standard size 22 mm tapered connector)	
Electrical rating	115 V - 230 V AC +10/-15 %, 50–60 Hz with power supply unit WM 24480 or 12 V - 24 V DC +25/-15 % with DC adapter WM 24469	
Power consumption in operation at		
230 V	0,1 A	0,23 A
115 V	0.2 A	0.45 A
24 V	0.9 A	2.0 A
12 V	1.8 A	4.0 A
Power consumption on standby at		
230 V	0.02 A	0.02 A
115 V	0.04 A	0.04 A
24 V	0.2 A	0.2 A
12 V	0.4 A	0.4 A

WM 67701b 06/2014

	Therapy device	Therapy device with humidifier
<b>Classification to EN 60601-1:2005</b> Type of protection against electric shock Degree of protection against electric shock Protection against damaging ingress of water Duty cycle	Protection class II Type BF IPX1 Continuous duty	
Electromagnetic compatibility (EMC) to EN 60601-1-2 Radio interference suppression Radio interference immunity	Test parameters and limit values can be obtained from the manufacturer on request. EN 55011 B EN 61000-4 Parts 2 to 6, Part 11	
Mean sound pressure level to EN ISO 17510-1:2009	Approx. 25.8 dB (A) at 10 hPa (corresponds to a noise level of 33.8 dB (A) )	Approx. 26.2 dB (A) at 10 hPa (corresponds to a noise level of 34.2 dB (A) )
CPAP operating pressure range	SOMNO <i>balance</i> / SOMNO <i>soft</i> 2: 4 hPa to 18 hPa SOMNO <i>balance</i> e / SOMNO <i>soft</i> 2e: 4 hPa to 20 hPa	
Pressure precision	±0.6 hPa (1mbar = 1 hPa ≈ 1cm H <sub>2</sub> O)	
Max. CPAP pressure in the event of a fault	< 40 hPa	

	Therapy device	Therapy device with humidifier
Maximum flow rate to EN ISO 17510-1:2002:		
<i>SOMNObalance</i>		
18 hPa		120 l/min
14 hPa		130 l/min
12 hPa		140 l/min
9 hPa		150 l/min
6 hPa		155 l/min
5 hPa		160 l/min
4 hPa		165 l/min
0 hPa		175 l/min
Tolerance		±15 l/min
<i>SOMNObalance e</i>		
20 hPa		115 l/min
15 hPa		125 l/min
10 hPa		145 l/min
5 hPa		160 l/min
0 hPa		175 l/min
Maximum flow rate to EN ISO 17510-1:2009		
<i>SOMNObalance / SOMNOsoft 2</i>		
18 hPa	125 l/min	122 l/min
15 hPa	135 l/min	132 l/min
11 hPa	149 l/min	146 l/min
8 hPa	160 l/min	156 l/min
4 hPa	172 l/min	166 l/min
<i>SOMNObalance e / SOMNOsoft 2e</i>		
20 hPa	124 l/min	123 l/min
16 hPa	138 l/min	137 l/min
12 hPa	153 l/min	150 l/min
8 hPa	167 l/min	163 l/min
4 hPa	181 l/min	172 l/min

	<b>Therapy device</b>	<b>Therapy device with humidifier</b>
Heating of respiratory air	2.5 °C (as per HMV [Heilmittelverordnung – German regulations governing pharmaceutical products])	Dependent on heating stage
Precision of dynamic pressure (short-term precision) with 10 breaths/min to EN ISO 17510-1:2009		
<i>SOMNObalance / SOMNOsoft 2</i>		
18 hPa	$\Delta p = 0.2 \text{ hPa}$	$\Delta p = 0.2 \text{ hPa}$
15 hPa	$\Delta p = 0.2 \text{ hPa}$	$\Delta p = 0.2 \text{ hPa}$
11 hPa	$\Delta p = 0.1 \text{ hPa}$	$\Delta p = 0.2 \text{ hPa}$
8 hPa	$\Delta p = 0.1 \text{ hPa}$	$\Delta p = 0.2 \text{ hPa}$
4 hPa	$\Delta p = 0.1 \text{ hPa}$	$\Delta p = 0.4 \text{ hPa}$
<i>SOMNObalance e / SOMNOsoft 2e</i>		
20 hPa	$\Delta p = 0.2 \text{ hPa}$	$\Delta p = 0.2 \text{ hPa}$
16 hPa	$\Delta p = 0.2 \text{ hPa}$	$\Delta p = 0.2 \text{ hPa}$
12 hPa	$\Delta p = 0.2 \text{ hPa}$	$\Delta p = 0.2 \text{ hPa}$
8 hPa	$\Delta p = 0.2 \text{ hPa}$	$\Delta p = 0.2 \text{ hPa}$
4 hPa	$\Delta p = 0.2 \text{ hPa}$	$\Delta p = 0.2 \text{ hPa}$

	Therapy device	Therapy device with humidifier
Precision of dynamic pressure (short-term precision) with 15 breaths/min to EN ISO 17510-1:2009		
SOMNO <i>balance</i> / SOMNO <i>soft</i> 2		
18 hPa	$\Delta p = 0.2$ hPa	$\Delta p = 0.3$ hPa
15 hPa	$\Delta p = 0.2$ hPa	$\Delta p = 0.3$ hPa
11 hPa	$\Delta p = 0.2$ hPa	$\Delta p = 0.3$ hPa
8 hPa	$\Delta p = 0.1$ hPa	$\Delta p = 0.3$ hPa
4 hPa	$\Delta p = 0.2$ hPa	$\Delta p = 0.3$ hPa
SOMNO <i>balance</i> e / SOMNO <i>soft</i> 2e		
20 hPa	$\Delta p = 0.3$ hPa	$\Delta p = 0.3$ hPa
16 hPa	$\Delta p = 0.3$ hPa	$\Delta p = 0.3$ hPa
12 hPa	$\Delta p = 0.3$ hPa	$\Delta p = 0.3$ hPa
8 hPa	$\Delta p = 0.3$ hPa	$\Delta p = 0.3$ hPa
4 hPa	$\Delta p = 0.3$ hPa	$\Delta p = 0.3$ hPa
Precision of dynamic pressure (short-term precision) with 20 breaths/min to EN ISO 17510-1:2009		
SOMNO <i>balance</i> / SOMNO <i>soft</i> 2		
18 hPa	$\Delta p = 0.5$ hPa	$\Delta p = 0.5$ hPa
15 hPa	$\Delta p = 0.4$ hPa	$\Delta p = 0.4$ hPa
11 hPa	$\Delta p = 0.3$ hPa	$\Delta p = 0.4$ hPa
8 hPa	$\Delta p = 0.3$ hPa	$\Delta p = 0.4$ hPa
4 hPa	$\Delta p = 0.3$ hPa	$\Delta p = 0.4$ hPa
SOMNO <i>balance</i> e / SOMNO <i>soft</i> 2e		
20 hPa	$\Delta p = 0.4$ hPa	$\Delta p = 0.4$ hPa
16 hPa	$\Delta p = 0.4$ hPa	$\Delta p = 0.4$ hPa
12 hPa	$\Delta p = 0.4$ hPa	$\Delta p = 0.4$ hPa
8 hPa	$\Delta p = 0.4$ hPa	$\Delta p = 0.4$ hPa
4 hPa	$\Delta p = 0.4$ hPa	$\Delta p = 0.3$ hPa

	Therapy device	Therapy device with humidifier
Precision of static pressure (long-term precision) to EN ISO 17510-1:2009	$\Delta p = 0.07$ hPa	
Fine filter, degree of separation to 1 $\mu\text{m}$ to 0.3 $\mu\text{m}$	$\geq 99.5$ % $\geq 85$ %	
Fine filter service life	approx. 250 hours in normal ambient air	
SD card	Memory sizes 256 MB to 8 GB can be used, interface compatible with SD physical layer specification, Version 2.0	

The right to make design modifications is reserved. All values determined under ATPD conditions (ambient temperature and pressure, dry).

**CE 0197**

### 11.1.2 Humidifier

	<b>SOMNOaqua</b>
Product class to 93/42/EEC	II a
Dimensions W x H x D in mm	140 x 100 x 121
Weight (excluding water)	300 g
Temperature range Operation Storage	+5 °C to +35 °C -40 °C to +70 °C
Permitted humidity for operation and storage	$\leq 95$ % relative humidity
Ambient pressure range	600 hPa to 1100 hPa
Electrical rating	24 V DC
Power consumption	20 VA
Classification to EN 60601-1 Degree of protection against electric shock	Type BF

	<b>SOMNOaqua</b>	
Electromagnetic compatibility (EMC) to EN 60601-1-2 Radio interference suppression Radio interference immunity	EN 55011 B EN 61000-4, parts 2 to 6, part 11	
Max. permitted filling quantity	300 ml	
Max. permitted operating pressure	20 hPa	
Max. permitted flow rate (free-flowing)	190 l/min	
Max. mask temperature	37° C	
Gas leakage at 20 hPa	not measurable	
Humidifier system output with humidifier stage 6: flow rate = 20 l/min flow rate = 30 l/min flow rate = 40 l/min at 23 °C and 65 % relative humidity	6.3 mg/l 6.8 mg/l 9.0 mg/l	
Pressure drop via the humidifier Flow rate = 30 l/min Flow rate = 60 l/min Flow rate = 90 l/min	On inspiration 0.2 hPa 0.7 hPa 1.4 hPa	On exhalation 0.2 hPa 0.5 hPa 1.0 hPa
	This pressure drop has no effect on therapy pressure.	

The right to make design modifications is reserved. All values determined under ATPD conditions (ambient temperature and pressure, dry).

**CE 0197**



### 11.1.3 Pressure/volume curve

#### **SOMNObalance / SOMNOsoft 2**

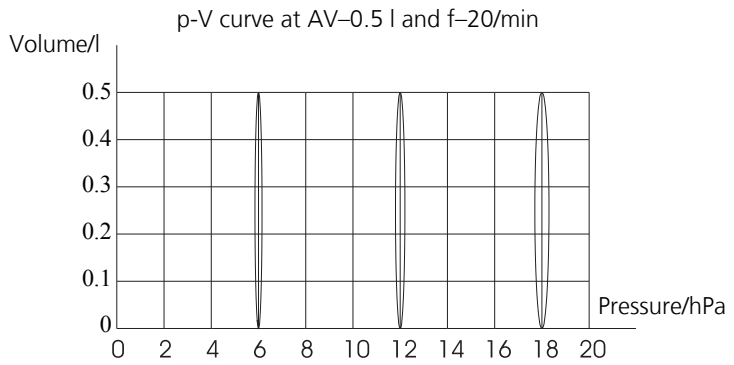

#### **SOMNObalance e / SOMNOsoft 2e**

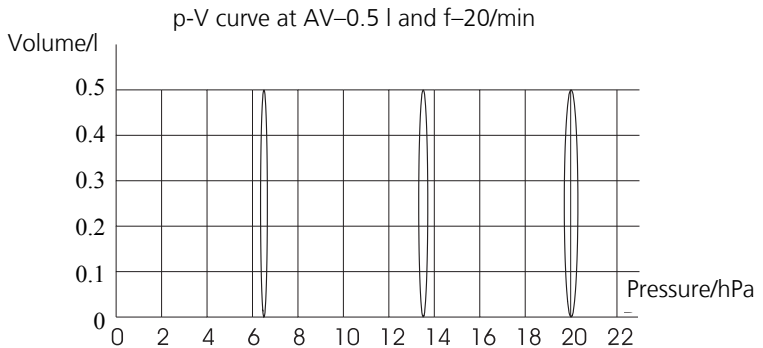

### 11.1.4 Pneumatic diagram

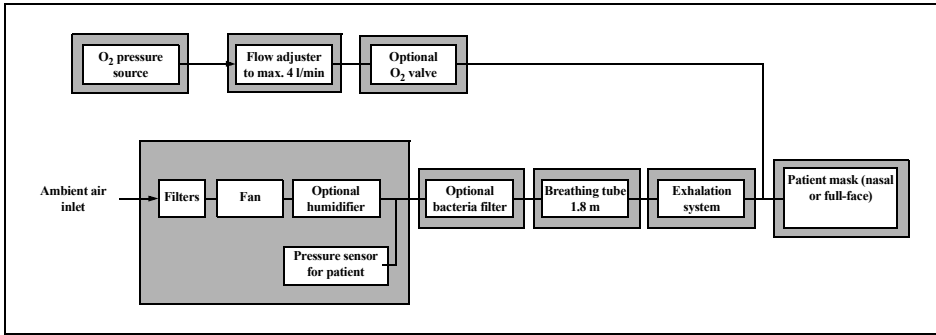

### 11.1.5 Safety distances

Recommended safety distances between portable and mobile HF telecommunication devices (e.g. cellphones) and the therapy device/SOMNOaqua			
Nominal power of HF device in W	Safety distance depending on transmission frequency in m		
	150 kHz - 80 MHz	80 MHz - 800 MHz	800 MHz – 2.5 GHz
0.01	0.12	0.12	0.23
0.1	0.37	0.37	0.74
1	1.17	1.17	2.33
10	3.69	3.69	7.38
100	11.67	11.67	23.33

## 11.2 Scope of supply

### 11.2.1 SOMNO*balance* (e)

Parts	Order number
<b>SOMNO<i>balance</i>, complete</b> <b>or</b> <b>SOMNO<i>balance</i> e, complete</b>	<b>WM 27410</b>
<b>each comprising:</b>	<b>WM 27420</b>
SOMNO <i>balance</i> or SOMNO <i>balance</i> e	WM 27411 WM 27421
Breathing tube	WM 24445
Power supply unit	WM 24480
Power cord	WM 24133
Instructions for use	WM 67701
Brief instructions for use	WM 67821
Carrying bag	WM 24449
Set of replacement filters (SOMNO <i>balance</i> only)	WM 15499
Patient record (SOMNO <i>balance</i> only)	WM 16162
SD card	WM 29791
Dispatch bag for SD card	WM 29779

### 11.2.2 SOMNO*balance* (e) with SOMNO*aqua*

Parts	Order number
<b>SOMNO<i>balance</i> with SOMNO<i>aqua</i></b> <b>or</b> <b>SOMNO<i>balance</i> e with SOMNO<i>aqua</i></b>	<b>WM 27450</b>
<b>each comprising:</b>	<b>WM 27460</b>
SOMNO <i>balance</i> or SOMNO <i>balance</i> e	WM 27410 WM 27420
SOMNO <i>aqua</i>	WM 24403

### 11.2.3 SOMNOsoft 2 (e)

Parts	Order number
<b>SOMNOsoft 2 with SOMNOaqua or SOMNOsoft 2e with SOMNOaqua each comprising:</b>	WM 29810
	WM 29820
SOMNOsoft 2	WM 29815
or SOMNOsoft 2e	WM 29825
Breathing tube	WM 24445
Power supply unit	WM 24480
Power cord	WM 24133
Instructions for use	WM 67701
Brief instructions for use	WM 67821
Carrying bag	WM 24449
Set of replacement filters (SOMNOsoft 2only)	WM 15499
Patient record (SOMNOsoft 2 only)	WM 16162
SD card	WM 29791
Dispatch bag for SD card	WM 29779

### 11.2.4 SOMNOsoft 2 (e) with SOMNOaqua

Parts	Order number
<b>SOMNOsoft 2 with SOMNOaqua or SOMNOsoft 2e with SOMNOaqua each comprising:</b>	WM 29850
	WM 29860
SOMNOsoft 2	WM 29810
or SOMNOsoft 2e	WM 29820
SOMNOaqua	WM 24403

### 11.2.5 Accessories

You can order accessories separately if required. A current list of replacement parts can be ordered from [www.weinmann.de](http://www.weinmann.de) on the Internet or via your specialist dealer.

## 11.2.6 Replacement parts

You can order replacement parts separately if required. A current list of replacement parts can be ordered from [www.weinmann.de](http://www.weinmann.de) on the Internet or via your specialist dealer.

## 11.3 Warranty

Weinmann gives the customer a limited manufacturer warranty on new original Weinmann products and any replacement part fitted by Weinmann in accordance with the warranty conditions applicable to the product in question and in accordance with the warranty periods from date of purchase as listed below. The warranty conditions can be downloaded from [www.weinmann.de](http://www.weinmann.de) on the Internet. We can also send you the warranty conditions on request.

In the event of a claim under warranty, contact your specialist dealer.

Product	Warranty period
Weinmann devices including accessories (except masks) for sleep diagnosis, sleep therapy, home ventilation, oxygen medicine and emergency medicine	2 years
Masks including accessories, rechargeable batteries, batteries (unless quoted differently in the technical documentation), sensors, tube systems	6 months
Disposable products	None

## 11.4 Declaration of conformity

Weinmann Geräte für Medizin GmbH + Co. KG hereby declares that the product complies with the relevant provisions of directive 93/42/EEC pertaining to medical devices. The complete text of the declaration of conformity can be found at: [www.weinmann.de](http://www.weinmann.de)





partner for life

**WEINMANN**  
medical technology

**Weinmann**

**Geräte für Medizin GmbH + Co. KG**

P.O. Box 540268 ■ D-22502 Hamburg

Kronsaalweg 40 ■ D-22525 Hamburg

T: +49-(0)40-5 47 02-0

F: +49-(0)40-5 47 02-461

E: [info@weinmann.de](mailto:info@weinmann.de)

[www.weinmann.de](http://www.weinmann.de)

**Center for**

**Production, Logistics, Service**

Weinmann

Geräte für Medizin GmbH + Co. KG

Siebenstücken 14

D-24558 Henstedt-Ulzburg

WM 67701b 06/2014 EN